

PFM - Semi Automatic Pouch Filler



POWER RATING +/- 1 KW
1PH 220 Vac + N + PE

DESCRIPTION

ENTRY LEVEL SEMI AUTOMATIC MACHINE FOR FILLING AND SEALING STAND POUCHES



SPECIFICATIONS

- Speed (Pack dependant)
- 10 to 12 packs per minute
- Wetted areas are 316L stainless steel
- Manual bag open & load
- Adjustable Volumetric piston filler (15ml to 200 ml)
- Automatic Index
- Automatic Sealing
- Automatic Offload

OPTIONS

- Volumetric Liquid Filling only
- Premeasured solid filling only
- Both Premeasured Solid Filling and Volumetric Filling

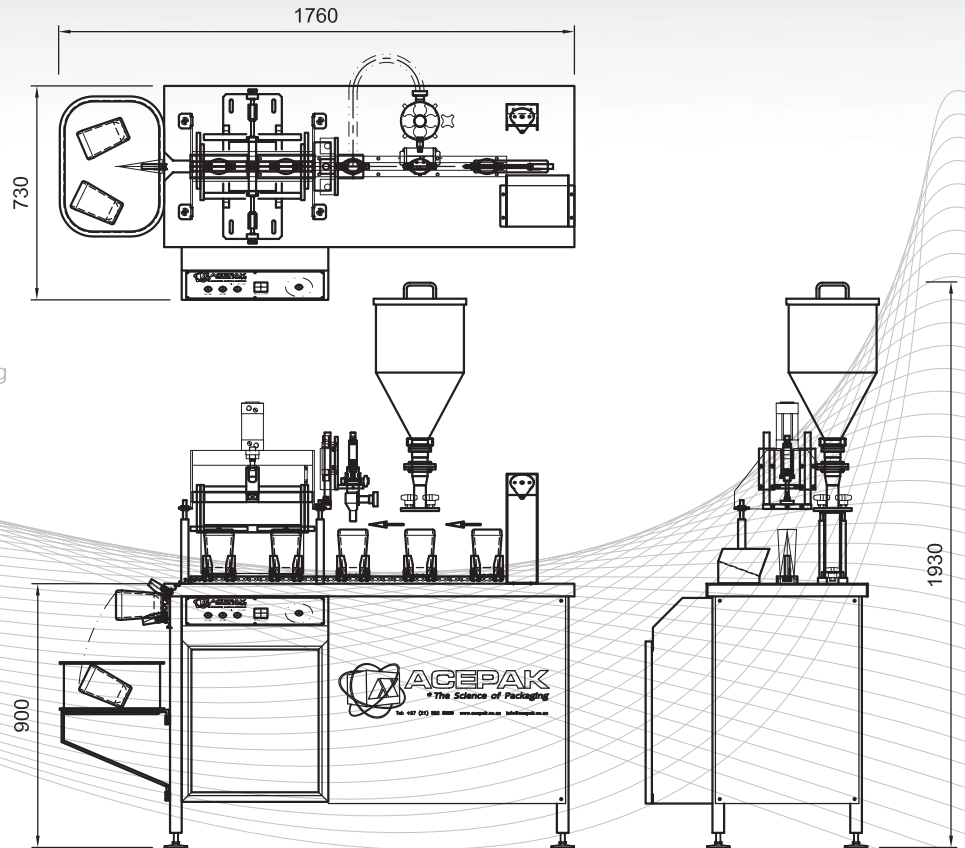

PF4H – Automatic Pouch Filler

with Optional Straw Inserter



POWER RATING +/- 7 KW
3PH 380 Vac + N + PE

DESCRIPTION

4 HEAD FULLY AUTOMATIC MACHINE FOR FILLING AND SEALING STAND UP POUCHES



SPECIFICATIONS

- Positive Drive Index
- Speed (Pack Dependant)
- Up to 100 packs per minute on 200g Packs
- Wetted areas are 316l Stainless Steel
- Pouches loaded into machine by operator
- For automatic loading onto index system
- Automatic Filling
- Automatic Indexing
- Automatic Sealing and Offloading
- No Bag, No Fill, No Sealing Features

OPTIONS

- Volumetric Piston liquid filling (pneumatic or servo controlled)
- Time based gravity Liquid Filling
- Liquid-Filling Only
- Premeasured Solid Fill Only
- Both Premeasured Solid Filling & Liquid Filling
- Constant heat sealing or impulse Heat sealing
- Pneumatic or Servo-controlled Bag Opening Mechanisms

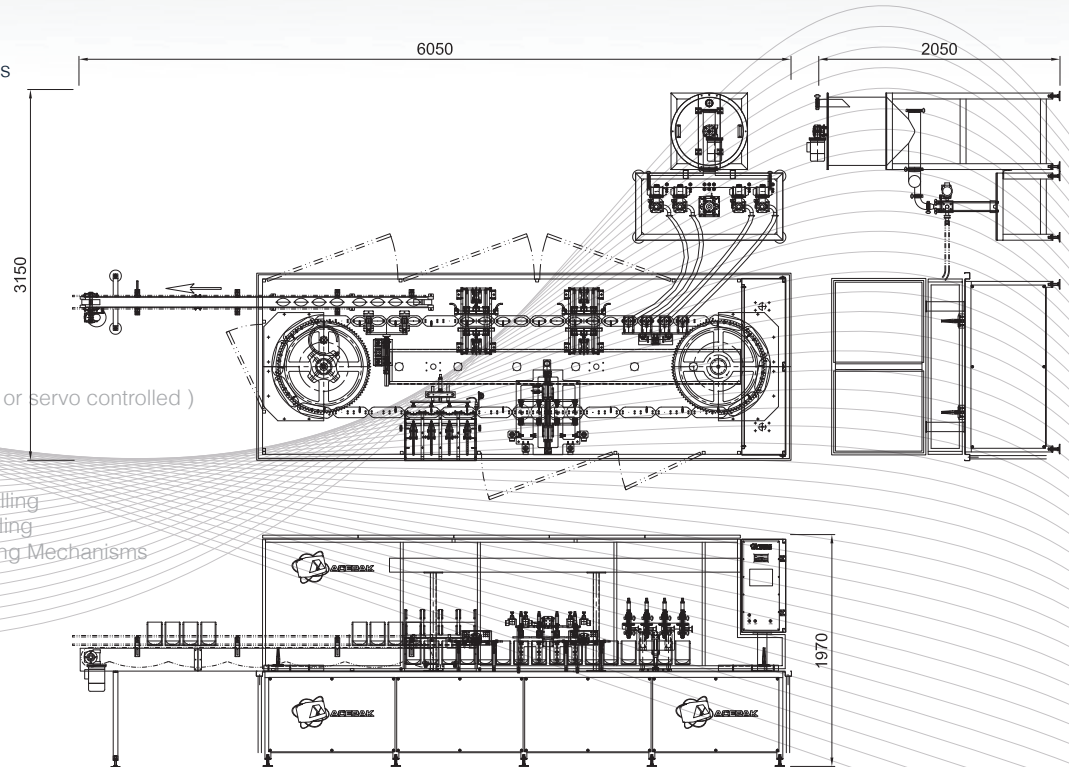

PF1 H – Automatic Pouch Filler

with Cup Doser



POWER RATING +/- 5 KW
3PH 380 Vac + N + PE

DESCRIPTION

1 HEAD FULLY AUTOMATIC MACHINE FOR FILLING AND SEALING STANDUP POUCHES



SPECIFICATIONS

- Speed (Pack Dependant)
- Positive Drive Index System
- 20-25 Packs per minute on a 400g Pack
- Wetted areas are 316L stainless steel
- Pouches are loaded into magazine by Operator
- For Automatic loading into Index System
- Automatic Filling
- Automatic Indexing
- Automatic Sealing & Offloading

OPTIONS

- Volumetric Piston liquid filling
- Time based gravity Liquid Filling
- Liquid Filling Only
- Premeasured Solid Fill Only
- Both Premeasured Solid Filling & Liquid Filling

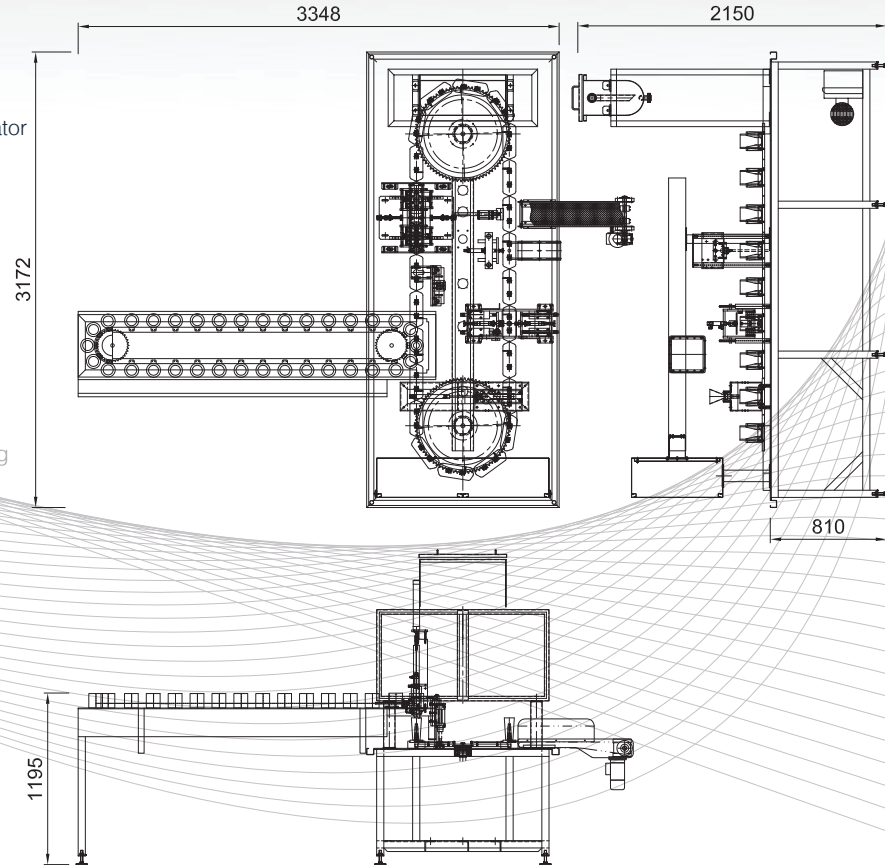

BFM - 2 Head Bag Filler



POWER RATING +/- 3 KW
1PH 220 Vac + N + PE

CF1H - Rotary Centre Fitment Pouch Filler



POWER RATING +/- 3 KW
3PH 380 Vac + N + PE

DESCRIPTION

1 HEAD FULLY AUTOMATIC CENTRE FITMENT POUCH FILLING AND CAPPING MACHINE



SPECIFICATIONS

- Speed (Pack Dependant)
- Typically up to 25 Packs per minute on 200g Packs
- Wetted areas / Food Contact areas are 316l Stainless Steel
- Pouches are loaded into machine for a Magazine / Rail
- For automatic loading onto index system
- Automatic Indexing
- Automatic Filling
- Automatic Pouch Offloading
- Volumetric Piston Filler Capacity Up to 1 litre
- Balancing Hopper with capacity up to 50 Litres
- Automatic Cap unscrambling with cap placement
- Automatic Cap Tightening
- Automatic Pouch Offloading
- No Fill Sensing
- Full Stainless Construction

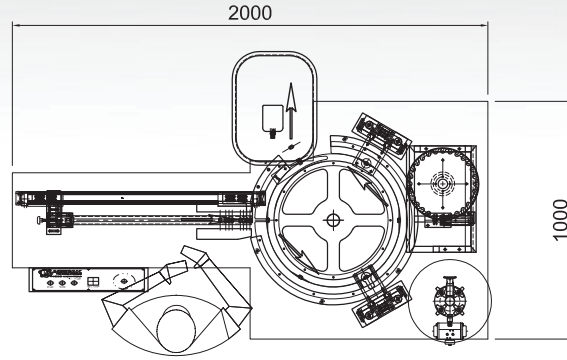

OPTIONS

- Vacuum function
- Gas function
- 1Ph 220vac + PE

